Link DDE Server for Windows® NT

Product Manual

Copyright © 2000 by Eurotherm Drives, Inc.

All rights strictly reserved. No part of this document may be stored in a retrieval system, or transmitted, in any form or by any means to persons not employed by a Eurotherm group company without written permission from Eurotherm Drives, Inc.

Although every effort has been taken to ensure the accuracy of this specification, it may be necessary, without notice, to make amendments or correct omissions in this document. Eurotherm Drives, Inc. cannot accept responsibility for damage, injury, or expenses resulting therefrom.

Printed in the United States of America 2000

HA470144 Issue 3



WARNING!

Only qualified personnel who thoroughly understand the operation of this equipment and any associated machinery should install, start-up, or attempt maintenance of this equipment. Non-compliance with this warning may result in serious personal injury and/or equipment damage.



WARNING!

Never work on any control equipment or motors without first removing all power supplies from the equipment.



Caution

This equipment contains ESD (Electrostatic Discharge) sensitive parts. Observe static control precautions when handling, installing, and servicing this device.



Caution

This equipment was tested before it left our factory. However, before installation and start up, inspect all equipment for transit damage, loose parts, packing materials, etc.



Caution

Ruptured semiconductor devices may release toxic materials. Contact Eurotherm Drives or the semiconductor manufacturer for proper disposal procedures for semiconductors or other material.

NOTE. The installation of this equipment must comply with the National Electric Code and any applicable local codes.

LINK DDE SERVER FOR WINDOWS® NT

CONTENTS

Chapter 1 - Hardware Installation

ABOUT THE DDE PACKAGE	1-1
CONTENTS	1-1
COMPUTER REQUIREMENTS	1-1
ADDITIONAL HARDWARE NEEDED	1-1
INSTALLATION	1-1
USING WINDOWS NT DIAGNOSTICS	1-2
DETERMINING AVAILABLE INTERRUPTS (IRQ'S)	1-2
Determining Available I/O Mapping	1-3

Chapter 2 - Software Installation

ENTERING THE LICENSE INFORMATION	2-10
Hardware Settings	2-11
Advanced Settings	2-12
Receive Rate (ms)	2-12
Link Buffer Size	2-13
Max Packets/Int.	2-13
Link Settings	2-14
Node Name	2-14
Link Address	2-14
Max Modules in Ring	2-14
Link Network Topology	2-14
Repeater Serial Number	2-14
Completing the Installation	2-15

Chapter 3 – Launching the Server

UNLICENSED PRODUCT WARNING	3-1
LINK DDE SERVER WINDOW	3-2
ENTERING YOUR PERMANENT LICENSE	3-2

Chapter 4 – Link Programming Example

PARAMETER READS	4 - 1
PARAMETER WRITES	4 - 1

Chapter 5 – GUI Programming Examples

GENERAL PROGRAMING INFORMATION	5 - 1
LINKDDE TOPIC AND ITEM SYNTAX	5 - 1
USER-DATA EXAMPLES	
Slot Read (Link output)	5 - 1
PREDEFINED ITEMS	5 - 2
USING MICROSOFT EXCEL®	5 - 3
DATA TYPES AND RANGES	5 - 3
SLOT READS	5 - 4
SLOT WRITES	5 - 5
USING WONDERWARE® INTOUCH	5 - 6
DATA TYPES AND RANGES	5 - 6
DATA ACCESS	5 - 7

Chapter 6 - Diagnostics & Troubleshooting

WINRT DEVICE DRIVER	6 - 1
L5204 LED STATUS	6 - 2
NT PERFORMANCE MONITOR	6 - 2
PERFORMANCE MONITOR COUNTERS	6 - 4
Link Network Loading	6 - 5
Configuration Problems	6 - 5
Network Problems	6 - 5
Server Performance Problems	6 - 5

Chapter 7 - Uninstalling the Server**Appendix A - L5206 Repeater Data Sheet****Appendix B - Link Card Blink Codes****Appendix C - Link Card Cable**

Chapter 1 – Hardware Installation

ABOUT THE DDE PACKAGE

CONTENTS

The L5204-DDE-NT Server package comes with the hardware and software needed to set up a DDE Link between a computer and a Link system. Please make sure you have received all the items in the following list.

Qty.	Eurotherm Part #	Description
1ea.	AH350634	L5204 DDE Card, 8 bit ISA Slot
1ea.	CM350901	DB25 Pin 1 meter Cable, DDE card to Repeater
1ea.	L5206-2-01	Link Gateway Repeater
1ea.	RD470144	V2.1 Link DDE-NT Server Software, 2 Disks

COMPUTER REQUIREMENTS

The L5204-DDE-NT Server requires a computer running Windows NT Version 4.x and at least one available ISA slot. The L5204 Interface Card which is supplied as part of the L5204-DDE-NT package installs into the ISA slot and requires an unused interrupt (IRQ) number and at least 64 bytes of I/O mapping space to work properly. Prior to installing the interface card, the user must determine the IRQ and I/O port mappings to be used by the card. This is easily accomplished using the diagnostics features of Windows NT.

ADDITIONAL HARDWARE NEEDED

The following hardware is also needed, but is not included in the L5204-DDE-NT package.

24Vdc Regulated Power Supply

Acrylic Fiber optic Cable (enough to connect Repeater to Link System)

Fiber optic Connectors (2ea. CI055069 – Red F/O Connectors,
2ea. CI055070 – Black F/O Connectors)

INSTALLATION

Before installing the card into the computer, you will need to find out what resources are available on your computer.

USING WINDOWS NT DIAGNOSTICS

Under the Start Menu, launch the Windows NT Diagnostics application in the Programs/Administrative Tools (Common) submenu.

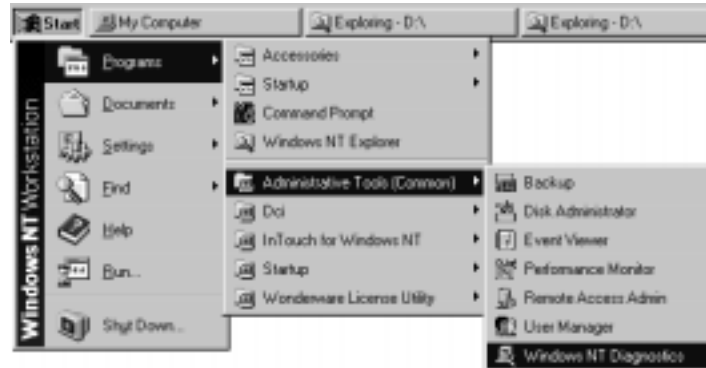

DETERMINING AVAILABLE INTERRUPTS (IRQ'S)

Once the Windows NT Diagnostics window appears, click on the Resources tab and determine an available interrupt (IRQ) for the L5204 Card. In the below example, IRQ7 is not currently used by any other resources on the NT machine into which we want to install the card, so it would be a valid selection.



Chapter 1 - Hardware Installation

The interrupt (IRQ) is selected on the L5204 interface card by using the rotary switch (SW2). Using the table below, turn the switch to position 5, which is IRQ 7.

Interrupt	Switch 2
IRQ 3	Position 1
IRQ 4	Position 2
IRQ 5	Position 3
IRQ 6	Position 4
IRQ 7	Position 5

Interrupt	Switch 2
IRQ 10	Position 6
IRQ 11	Position 7
IRQ 12	Position 8
IRQ 14	Position 9
IRQ 15	Position 10

NOTE: IRQ 10 - 15 only available with OPT-5 bus extension installed.

Determining Available I/O Mapping

With the Resource tab still selected, click once on the I/O Port button in the Windows NT Diagnostics window to view the I/O port addresses currently used by other devices on your computer. As can be seen from the following example, the space from 200 through 23F is not currently used by any other devices on the NT machine into which we want to install the card and would be a good selection.



The port mapping is set on the L5204 Interface card, by using the four position DIP switch (SW1). Using the table below set the switches to address 0200.

Address	Position 1	Position 2	Position 3	Position 4
0000	OFF	OFF	OFF	OFF
0040	OFF	OFF	OFF	ON
0080	OFF	OFF	ON	OFF
00C0	OFF	OFF	ON	ON
0100	OFF	ON	OFF	OFF
0140	OFF	ON	OFF	ON
0180	OFF	ON	ON	OFF
01C0	OFF	ON	ON	ON
0200	ON	OFF	OFF	OFF
0240	ON	OFF	OFF	ON
0280	ON	OFF	ON	OFF
02C0	ON	OFF	ON	ON
0300	ON	ON	OFF	OFF
0340	ON	ON	OFF	ON
0380	ON	ON	ON	OFF
03C0	ON	ON	ON	ON

With the settings for both the IRQ and the I/O Port Mappings set, install the L5204 interface card into your computer and continue with the software installation in Chapter 2.

Chapter 2 - Software Installation

To install the DDE NT Server, the user **MUST** be logged on to the destination NT machine as an Administrator (or have Administrative rights). Installation is similar to that of other native Windows NT applications.

NOTE: It is strongly recommended all other applications be closed prior to starting the DDE Server software installation process.

To begin the installation process, place Disk 1 of the installation into your floppy disk drive on your PC and choose the Run command from the Start Menu.



When the following window appears, type in a:\Setup.exe (assuming your floppy disk drive is the a: drive) and click the OK button.

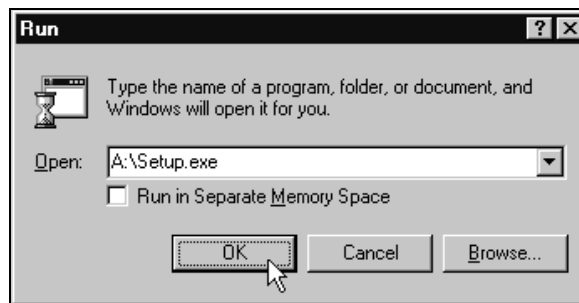

At this point, the Link DDE install wizard will launch and display a progress indicator bar with the percentage of completion.

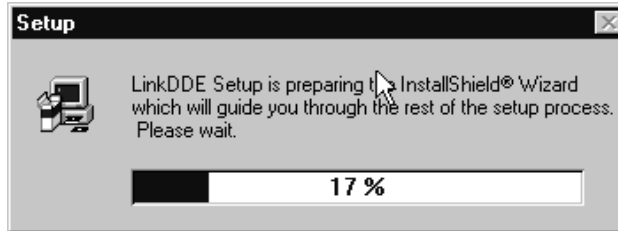

When the Welcome Screen appears, hit the <Next> button when you are ready to proceed. If you wish to abort the installation, select the Cancel button.

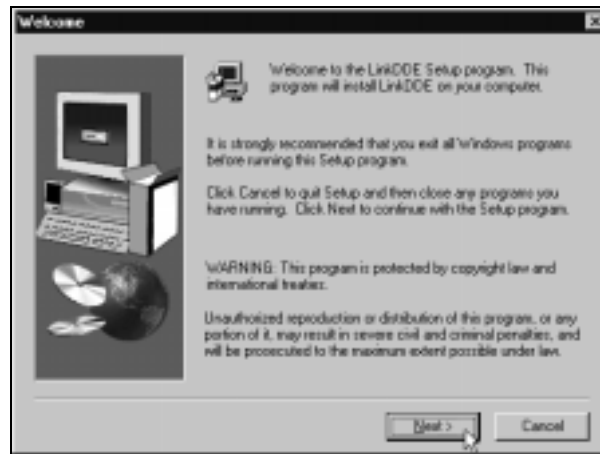

Chapter 2 - Software Installation

A User Information screen will appear with the default information for the NT machine on which you are installing the server. If you would like to modify this registry information, simply type in the desired changes. After all changes have been made, click on the Next > button.

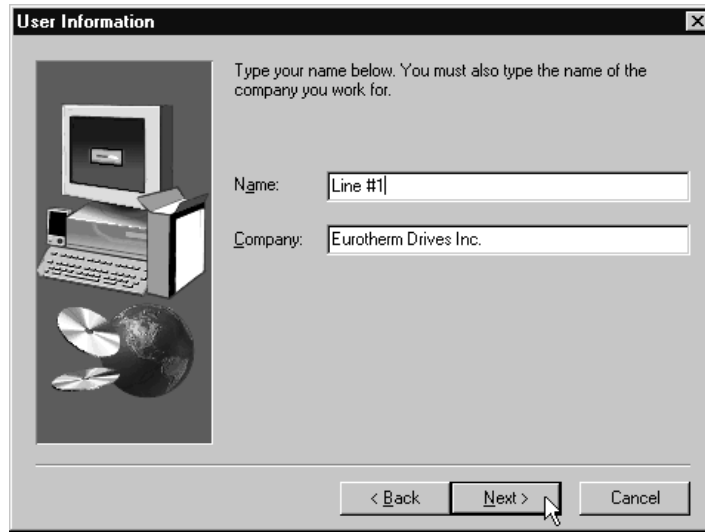

The Choose Destination Location window will now appear allowing you to specify the folder to be created by the install wizard (default is Program Files\DCI\LinkDDE). If you want to change the destination, click on the Browse button.

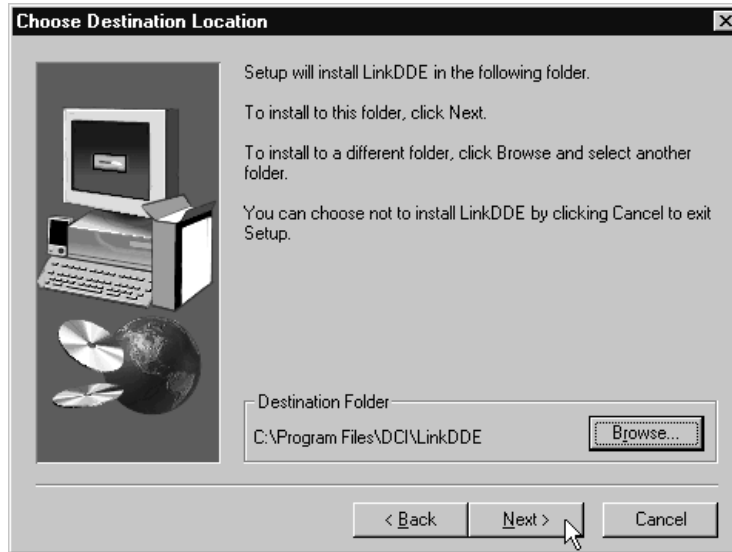

The Choose Folder window will appear where a drive and folder may be specified. If the <Browse> button is clicked, specify the desired path and hit the <OK> button.



Chapter 2 - Software Installation

If the Destination Folder does not already exist, the install wizard will prompt you for confirmation prior to creating the folder. Click the <Yes> button to accept the destination, or click the <No> button to re-enter the destination.



Next, you will be prompted for the folder into which you would like the Server to be installed. Either accept the default, DCI, or change the folder by typing in the desired folder name, or pick one from the existing folder list. Click the <Next> button to continue.



Once the program folder has been created, the installation wizard must expand all the compressed files from the floppies onto your computer. The expansion will take a few minutes during which the following progress indicator will appear.

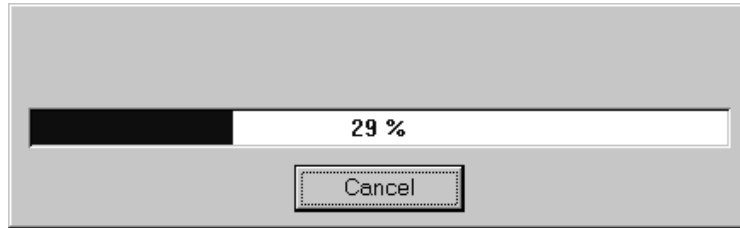

ENTERING THE LICENSE INFORMATION

At this point in the installation process, the Registry Editor screen will appear. The Link DDE Server is supplied from the factory with a temporary license, which will allow the user to install and use the server for a limited period of time (specified by the Termination Date). If you have obtained your permanent license prior to installing the Server, click the modify button at this point to enter all your company's licensing information. If not, simply click the OK Button to continue with the installation process.

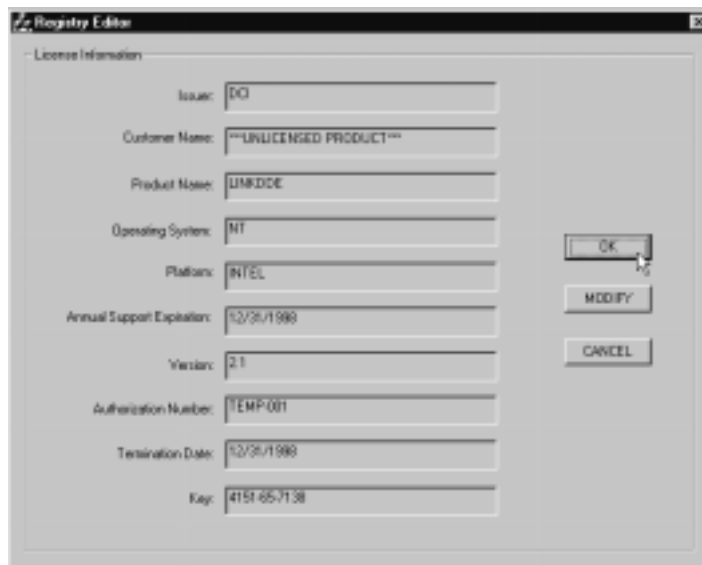

SETTING UP THE DDE SERVER

After entering your licensing information, the Link DDE Setup screen will appear (shown below). At this point, look on your L5206 Gateway Repeater module and note the serial number from the bar code label (for example, 9740USH0121). Enter the serial number in the following format, XXXX-XX-X-XXXX.

IMPORTANT: The serial number must be entered correctly for the server to function.

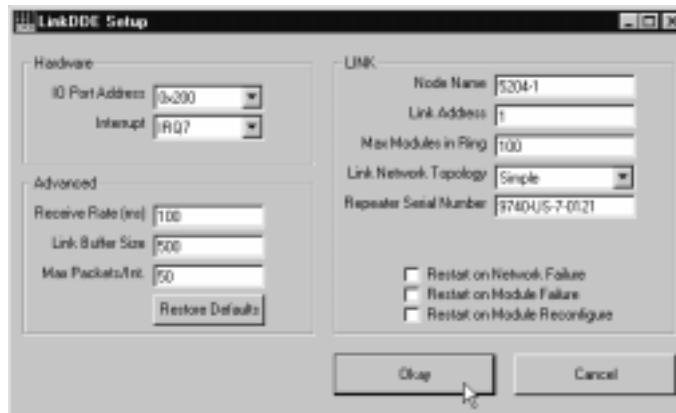

Hardware Settings

Click on the arrow to the right of the I/O Port Address field. A pick list will appear with all the possible hexadecimal address settings of Switch 1 on the L5204 card. Select the appropriate setting based the switch settings you chose in Chapter 1 - Hardware Installation.

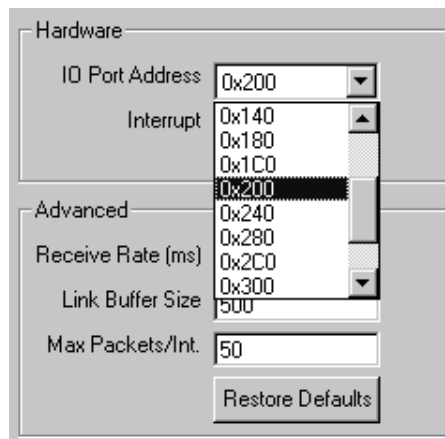

Now, click on the arrow to the right of the Interrupt field to open the list window. A pick list will appear with all the possible interrupt settings of Switch 2 on the L5204 card. Select the appropriate setting based the rotary switch position you chose in Chapter 1 - Hardware Installation.

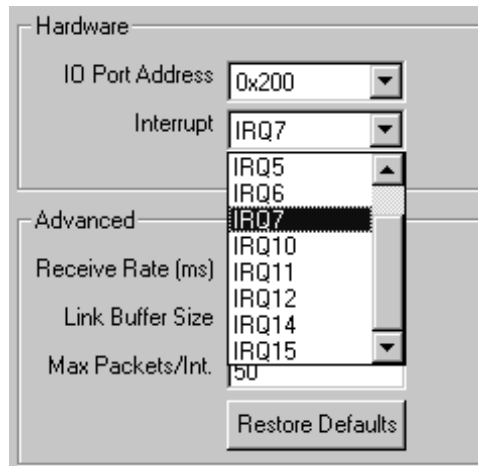

Advanced Settings

Generally, the default values in the Advanced section of the Link DDE Setup screen will not require modification. If you notice poor performance of the server (delays in receiving or transmitting data from the server), use the counters described in Chapter 6 - Diagnostics & Troubleshooting to monitor the performance. If the In FIFO Overflow and Link Buffer Overflow counters continuously increase, you may have to adjust the following settings.

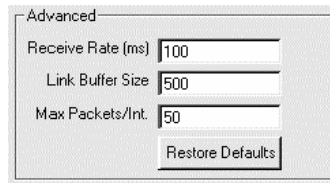

Receive Rate (ms)

The Receive Rate parameter defines the cycle time for processing messages. The default of 100ms provides excellent update rates for incoming messages; however, in rare instances, this rate may require tuning.

Increasing the Receive Rate (>100ms) reduces CPU loading on the NT computer and slows updates times on displayed parameters. Decreasing the Receive Rate improves update times, but may overload the CPU.

Link Buffer Size

This parameter allocates computer memory for the Link message buffer. While the default value of 500 will suffice in most applications, if you see significant delays in data update times, this buffer size may have to be increased. The Link Buffer Overflow counter described in Chapter 6 - Diagnostics & Troubleshooting will assist you determining the correct Link Buffer Size.

Increasing the Link Buffer Size prevents buffer overflows and improves performance, but may cause “Out of Memory” errors if the computer runs out of RAM. Decreasing the Link Buffer Size will free up RAM memory for other applications, but may cause Link Buffer Overflows.

Max Packets/Int.

The Max Packets/Int. parameter determines the number of incoming messages that can be processed per interrupt. The default value is 50 and should be adequate for all except the most heavily loaded Link networks. The In FIFO Overflow counter described in Chapter 4 – Diagnostics & Troubleshooting will assist you determining whether the best Max Packets/Int setting.

On heavily loaded Link Networks, decreasing the Max Packets/Int. will cause In FIFO Overflows to occur and result in the loss of incoming message packets. Lost packets causes excessive latency in updates of the data coming into the DDE Server (Link Inputs to the Server). Increasing the Max Packets/Int. will prevent In FIFO Overflows and improve performance, but may delay data being sent from the DDE Server to other nodes on the Link Network (Link Outputs from the Server).

Link Settings

The Link settings affect the way the DDE Server performs on the Link Network.

Node Name

The Node Name parameter is a text field that specifies the name as it will appear in a Full Update of a ConfigEd Module List.

Link Address

The Link Address parameter specifies the Link DDE Server's address on the Link Network. The specified address must be unique on the user's network and in the range from 1 to 3000.

Max Modules in Ring

The Max Modules in Ring parameter allocates resources for the Link DDE Server at initialization. The entered value MUST equal or exceed the actual number of nodes on the Link Network.

Link Network Topology

The pull down list for the Link Network Topology includes choices for Simple, Tapped, Redundant, and Aux Tapped. Select the appropriate topology based on the fiber optic cable routing you have planned (see Appendix A - L5206 Repeater Data Sheet).

Repeater Serial Number

Insert dashes in the appropriate locations in the repeater's serial number you noted at the beginning of this section (for example, the value of 9740USH0121 must be entered 9740-US-H-0121 or the Link DDE Server will not operate properly).

NOTE. Failure to enter a valid serial number will prevent the Link DDE Server from operating properly.

Completing the Installation

After entering all the Hardware Settings, click the Okay button at the bottom of the Link DDE Setup screen. At this point, a final Link DDE Setup screen will appear. The computer must be restarted for the changes to take effect.

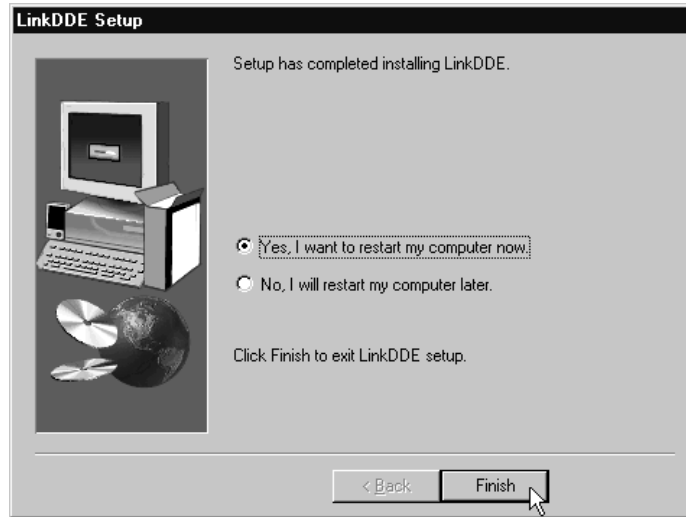

The L5206 Repeater Module in your Link Network must be powered and connected to the L5204 Card in your computer before the Link DDE server changes will install.

Pick the No selection prior to clicking the Finish button if you must complete the Link system installation. Perform a normal shut down of the NT machine and power down the computer to complete the necessary installations.

Chapter 3 – Launching the Server

After installing the DDE Server, you will see a new icon on the Desktop of your machine (shown below). Double-clicking the Link DDE shortcut will launch the Server. If you want the server to run automatically at power-up, copy the shortcut to the Startup Folder for the machine (typically in the Windows NT installation directory of *WinNT\Profiles\All Users\Start Menu\Programs\Startup*).



UNLICENSED PRODUCT WARNING

As shipped, the DDE Server is an unlicensed product. Until properly registered the following dialog box will appear:



Whenever the Server is launched, the user must check all of the boxes in the dialog box and the click the OK button. This cumbersome dialog box will disappear when the software has been properly registered.

LINK DDE SERVER WINDOW

After launch, the Link DDE window will appear with some commonly used diagnostics visible in the window. The diagnostics are described in Chapter 4 – Diagnostics & Troubleshooting.

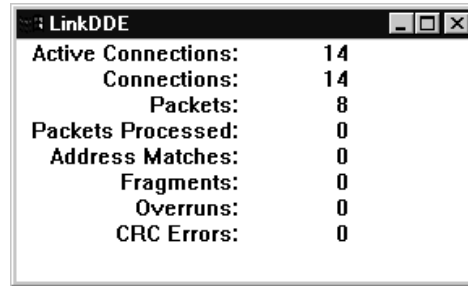

LinkDDE	
Active Connections:	14
Connections:	14
Packets:	8
Packets Processed:	0
Address Matches:	0
Fragments:	0
Overruns:	0
CRC Errors:	0

If all is well, the LED on the L5204 Card in your NT computer should be solid green and you should see a non-zero number in the Packets field. At this point, the Server may be used to send/receive information to/from the Link Network.

If the LED on the L5204 is not solid green, follow the techniques of Chapter 6 - Diagnostics & Troubleshooting to resolve the problem.

ENTERING YOUR PERMANENT LICENSE

After obtaining your permanent license for the DDE Server, you must enter your license information. Use the License Editor utility provided with the Link DDE Server to modify your licensing information. It is in the folder specified during the initial installation (typically *Programs\Dci\LinkDDE\License Editor*).

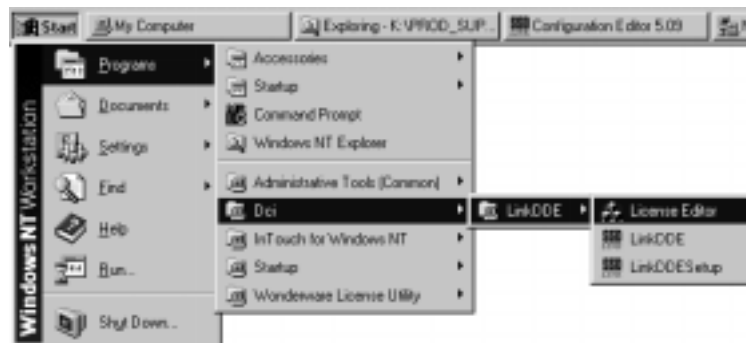

At this point, the Registry Editor screen which originally appeared during the initial installation of Chapter 2 - Software Installation will reappear. Click the Modify button and enter the licensing information EXACTLY as it appears on the licensing documentation supplied by your vendor.

Chapter 4 – Link Programming Example

The programming in Link is fairly straight forward. The only blocks you will need to use are the Link input and output blocks. There is not a specific function block in Link for the DDE Sever, so you do not have to program the DDE card in ConfigEd.

The address of the Link input and output blocks has to match the address set in the DDE server software – Chapter 2. Each input or output block must have an individual slot number between 1 and 3000. For further information on addressing, slot numbers and types of numbers, refer to the ConfigEd Manual.

PARAMETER READS

To read a parameter from Link, the source module must have a corresponding Link output in the configuration. In Chapter 2 the address of the DDE Server was set at 1. The type of output (Value, Logic or Ordinal) does not matter in Link, it will be defined in the GUI software.

The following is an example of a logic output parameter sent from a Link module to the DDE Server at Address 1 Slot 52. The GUI interface will have a corresponding Read to handle the information. This is all that is needed in the configuration to Read the information.

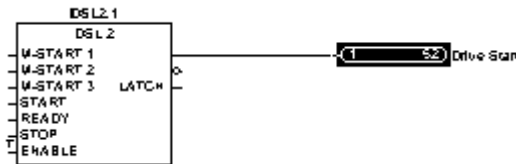

PARAMETER WRITES

To write a parameter to Link, the destination module must have a corresponding Link Input. The GUI software will handle the type of write; all Link needs to know is where to put the information. The following is an example of a Draw setpoint parameter from the DDE Server, Address 1 Slot 61, connected to the Draw Sp connector on the Section Control block SC.1.

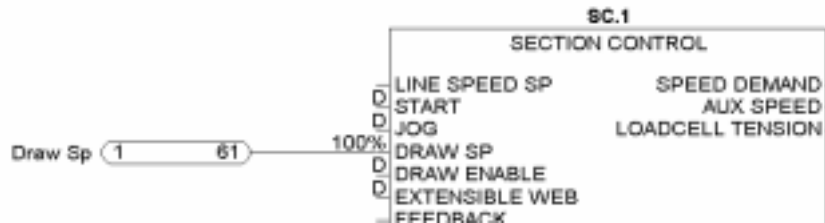

Chapter 5 – GUI Programming Examples

There are many GUI interfaces available that can communicate through a DDE interface. We are only going to cover Microsoft Excel and Wonderware Intouch.

GENERAL PROGRAMING INFORMATION

DDE uses the syntax : **Application | Topic ! Item** to address parameters. It is important to recognize that this is often just a notation. While some applications (Microsoft Excel) use this syntax literally, others (Wonderware InTouch) use three separate strings.

As the name suggests, the application component identifies the “serving” application. Windows NT requires it to be the servers’ filename (no extension). The *Link* DDE Server’s application name would be **LinkDDE**. The servers define the syntax for their topics and items since only they know the addressing requirements for the data that they handle. Client applications must observe the topic and item syntax for the servers they use.

LINKDDE TOPIC AND ITEM SYNTAX

To transmit data from a client/supervisor to the Link network, the Link DDE Server must be given four things (in addition to the data itself):

- The ring number and destination module, specified by the topic: (with Windows NT there can only be 1 ring).
- The destination slot number and the data type, specified by the item.

These are mapped to DDE components through the topic and item.

To provide Link data to a client/supervisor, the Link DDE Server needs the same information with the exception that no module is specified because, in Link, the receiver of a message does not care which module sent it.

Ring and slot numbers are integer numbers. Modules can be specified either by a literal address (a decimal number preceded with a + sign) or by configuration name. Data Type is specified by appending one of V, O, or L (representing Link types: Value, Ordinal, and Logic, respectively) to the slot number. While type suffixes are not case sensitive, to avoid letter/digit confusion, we recommend using lower case “v”, “o” and upper case “L”.

USER-DATA EXAMPLES

Slot Read (Link output)

To receive an ordinal from slot number 125 on ring 1:

```
linkdde|1!125o
```

Slot Write (Link input)

To send a value to slot number 210 of a module named 5300-11 on ring 1:

```
linkdde|1.5300-11!210v
```

To send a logic to slot number 45 of a module at address 20 on ring 1:

```
linkdde|1.+20!45L
```

NOTE: Like a normal Link module, the Link DDE Server actively writes and passively reads. There is no polling. Because of this, every slot-write or slot-read is by definition either an input or an output; **it cannot be both**. The module specifier (.5300-11 or .+20, above) in the Topic string makes it an output (server to LINK) rather than an input (Link to server).

PREDEFINED ITEMS

Predefined Items allow the server to inform the client application about items outside the user-data space (for example, communication errors). Because this information exists outside the user-data space, the user-defined items' syntax cannot be used. Predefined Items are also inherently read-only because they indicate only status. This indication is:

0 = Server Problem

1 = Server OK

Wonderware defined STATUS as the one Predefined Item that all servers must provide. STATUS returns a Boolean (that is Pass/Fail) indication of successful communication with a particular topic.

Eurotherm Drives defined an additional Predefined Item: STATES. STATES expands the Pass/Fail information available to the client by providing the state of the target module. It returns a 16-bit unsigned integer that will have exactly one bit set. (The most significant bit is not used.) The set bit shows the state of the target module as follows:

14	13	12	11	10	9	8	7	6	5	4	3	2	1	0
Un- Known	Debug	Dup. Adrs.	Peer Halted	Check Net	OK Net Fail	OK Net Warn	OK	Shut- Down	Self Test Failed	H Error	L Error	No Config	Halted	Init

The unknown bit does not represent a real module state. It shows that the server is unable to communicate with the module and cannot determine its state.

Decoding STATES allows the user to determine the state of each module on the network (when STATES numbers 7 or 8 are true). This makes the STATUS item unnecessary.

Examples

1. STATUS and STATES for server module itself.
 To obtain meta-information on the server for ring 1:
 linkdde|1!STATUS Returns 0 (fault)/1 (OK).
 linkdde|1!STATES Returns the unsigned integer bitfield described earlier.

2. STATUS and STATES for remote module
 To obtain the status of communication with a module named MAIN on ring 1:
 linkdde|1.MAIN!STATUS Returns 0 (fault)/1 (OK).
 To obtain the state of a module at address 20 on ring 1:
 linkdde|1.+20!STATES Returns the unsigned integer bitfield described above.

Note: In example 2 above, the items read from a topic that specifies a module. For slot-based transfers, the topics can use only output items.

USING MICROSOFT EXCEL®

DATA TYPES AND RANGES

The correspondence between the three Link data types and native Excel types is shown below. Each type has an allowed range. Note that Excel doesn't distinguish between whole and real numbers. Also recall that Link considers ordinals to be unsigned.

LINK	Excel	Server to Excel	Excel to server	Inherent Unit
Logic	Logical	FALSE, TRUE	FALSE, TRUE	<none>
Ordinal	Number	[0, 65535]	[0, 65535], trunc. To 16 bit unit	<none>
Value	Number	[-100.0,+100.0]	[-100.0,+100.0], clamped	%

SLOT READS

Inputs from the Link DDE server to an Excel spreadsheet are easy to create

To read data into a cell, enter the DDE address into the cell as a formula. For Example, to receive an ordinal from slot number 125 on ring 1 use:

=linkdde|'1'|'125o'

NOTE: Remember that a formula must start with the “=” character.

The apostrophes are required for any component that starts with a digit or contains spaces.

Here is an example from Excel 97.

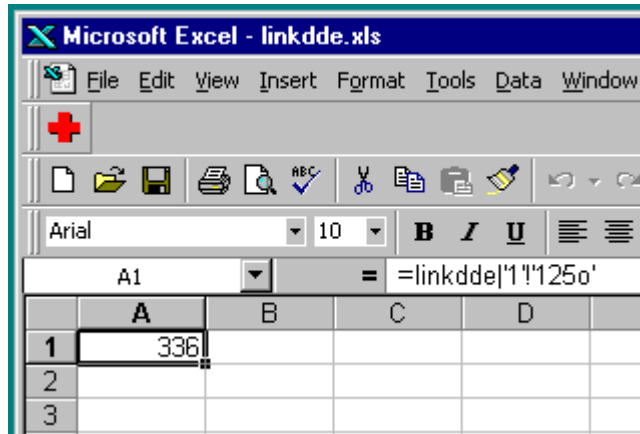

Cell A1 in the Excel spreadsheet is reading the following :



It is an Ordinal pot loaded into a L5392 Link OP Station.

SLOT WRITES

The following Excel spreadsheet writes data from Cell, A1 through the Link DDE Server to Link Address 400 Slot 210. The figure below shows the Excel program (macro). You must run the macro each time you want to write the data to Link.

2. Create a Macro called Send_data.

```
Sub send_data()  
send_channel = Application.DDEInitiate("LinkDDE", "1.+400")  
Set rangetopoke = Cells(1, 1)  
Application.DDEPoke send_channel, "210v", rangetopoke  
Application.DDETerminate send_channel  
End Sub
```

Example from Excel 97.

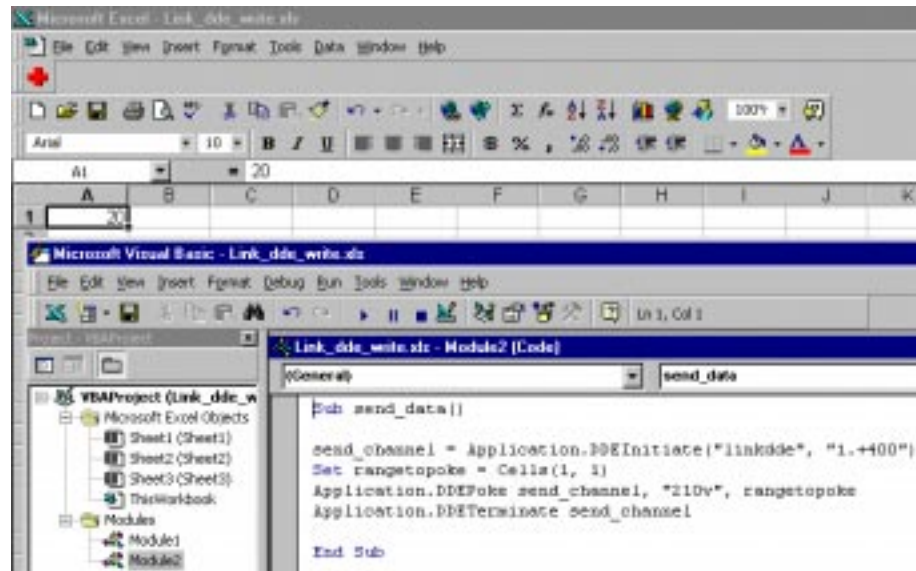

2. Place the data in Cell A1 to be written.
Enter 20 in A1
3. Run the Macro Send_data
Tools::Macro::Run::Send_data
4. Read the Data in LINK.
SAM the module and input slot. The slot should contain the number '20'.

This figure shows the Link configuration for a meter in a L5392 Op Station. The Link DDE server writes to the input slot at Address 400 Slot 210.

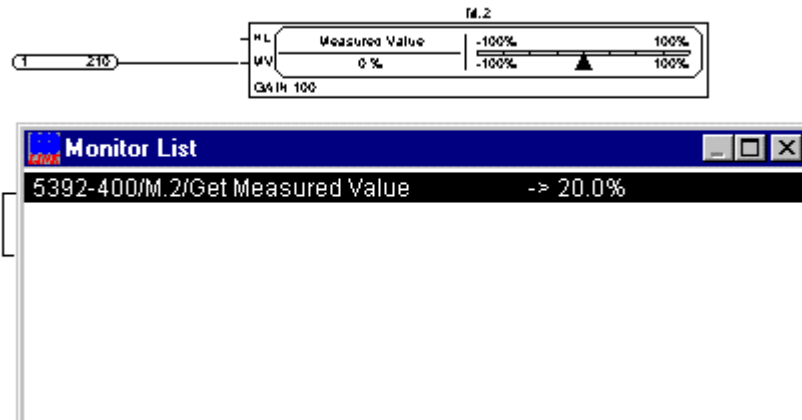

The Monitor List figure above shows the value Link received from Excel.

USING WONDERWARE® INTOUCH

Before starting this section, you should have a good working knowledge of Intouch software and have it loaded on your computer.

DATA TYPES AND RANGES

There is a one-to-one correspondence between the three *Link* data types and native Wonderware types. Each type has an allowed range. Also recall that *Link* considers ordinals to be unsigned.

Link	Wonderware	Server to Viewer	Viewer to Server	Inherent Unit
Logic	Discrete	FALSE, TRUE	FALSE, TRUE	<none>
Ordinal	Integer	[0, 65535]	[0, 65535], trunc. To 16 bit unit	<none>
Value	Real	[-100.0,+100.0]	[-100.0,+100.0], clamped	%

DATA ACCESS

Wonderware holds all system data in registers called 'Tag Names' or tags. Tags allow access to data outside of Wonderware. For efficiency, Wonderware uses another layer of indirection between the tags and the DDE servers called 'Access Names'. We first have to create the 'Access Names' so they can be called out in the tags.

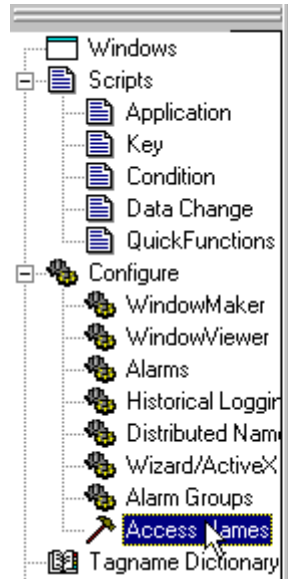

Create 'Access Names' for each unique Topic to be accessed. First we will create a read 'Access Name' called link_read (only one read access name needed for a project).

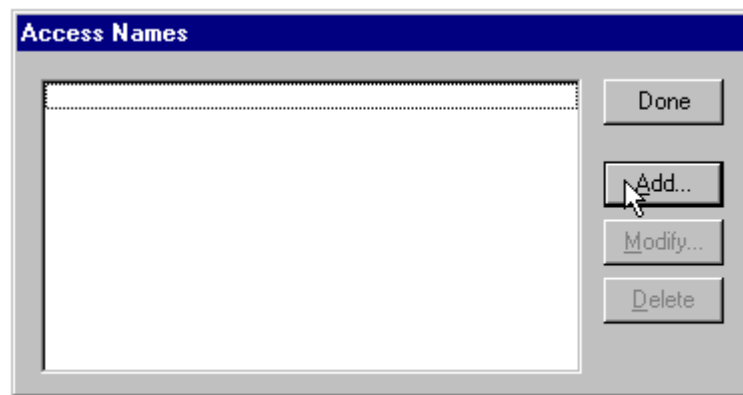

Modify Access Name

Access Name: link_read

Node Name:

Application Name: linkdde

Topic Name: 1

Which protocol to use

DDE SuiteLink

When to advise server

Advise all items Advise only active items

OK

Cancel

Type in the above information and then click <OK>.

Node Name: Only needed if you have multiple computers on the system network

Application Name: Name of the DDE server software

Topic Name: Link address for the DDE server

Next, Create an 'Access Name' for each Link address receiving data. The following example is for module address 400 and Link DDE address of 1. The 'Access Name' is the module type and its address.

Modify Access Name

Access Name: 5392-400

Node Name:

Application Name: LinkDDE

Topic Name: 1.+400

Which protocol to use

DDE SuiteLink

When to advise server

Advise all items Advise only active items

OK Cancel

The 'Access Name' Dialog box below also has an 'Access Name' for a 590 DC drive, Address 10.

Access Names

5392-400
L590-10
link_read

Done
Add..
Modify..
Delete

Now that the 'Access Names' are completed we can move on to setting up the tags.

A tagname will have to be created for each slot input and output. All the tags are setup in the Tagname Dictionary.

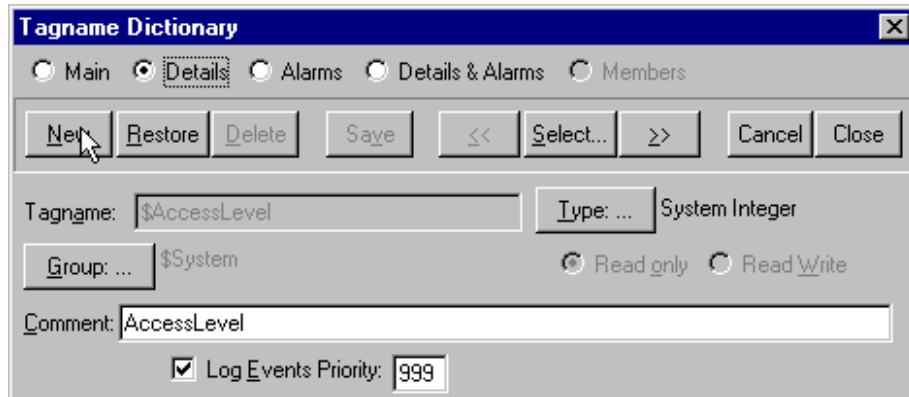
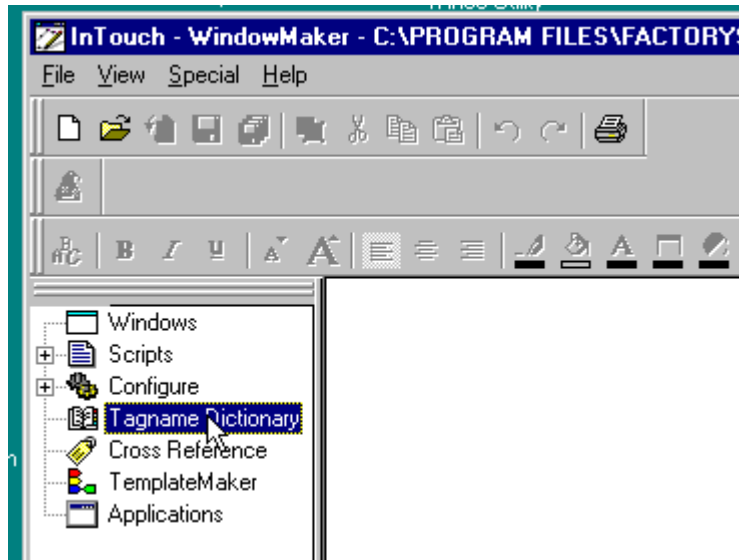

Click on <New> to create a new tagname.

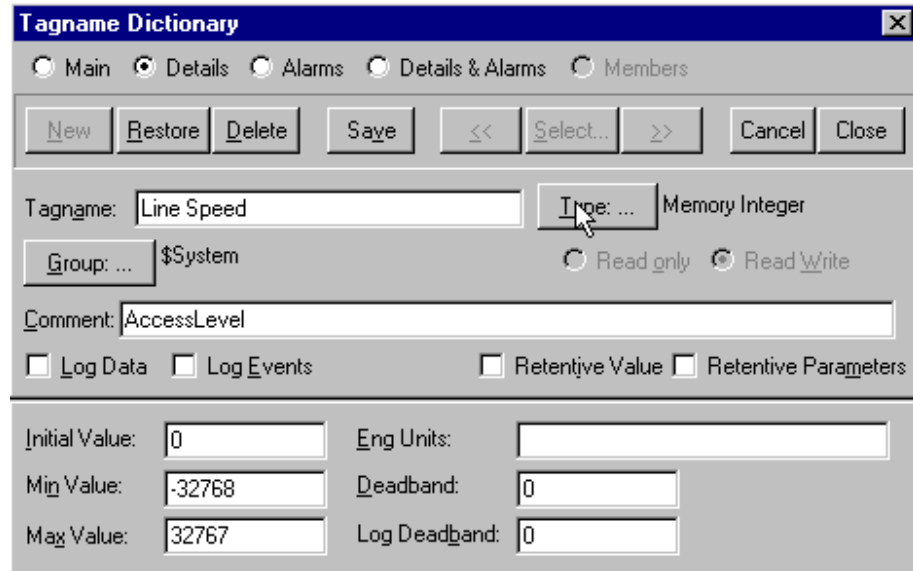

Type in the new tagname <Line_Speed>. Then click on Type to choose the data type to be accessed. Since this is a value, we will choose I/O Real.

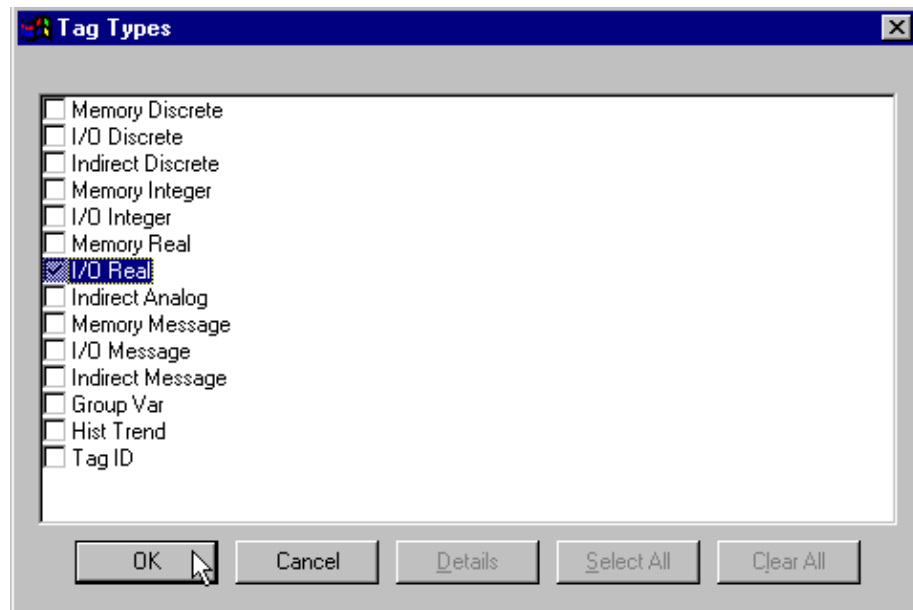

After choosing the type, you will notice that the tagname window has changed to look like the following.

Enter in the following information:

Group: Stays the same at \$System
 Choose : Read only – because this is a slot read
 Initial Value: Enter if needed
 Min EU: 0 (minimum value)
 Max EU: 100
 Deadband: 0
 Min Raw: 0
 Max Raw: 100
 Eng Units: Required engineering units

Now an 'Access Name' has to be assigned to the tag name. Click the 'Access Name' button.

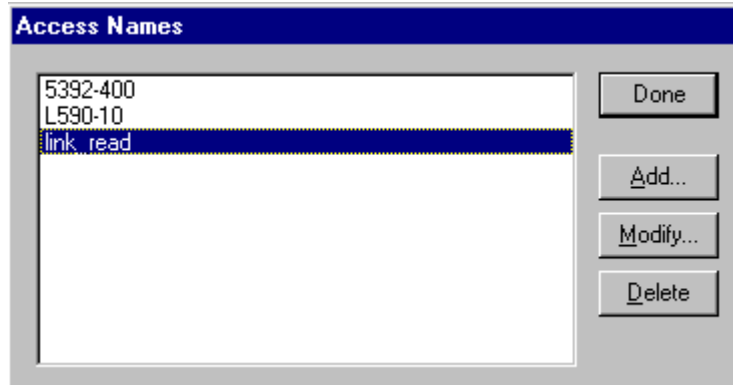

After choosing <link_read>, click on <Done>.

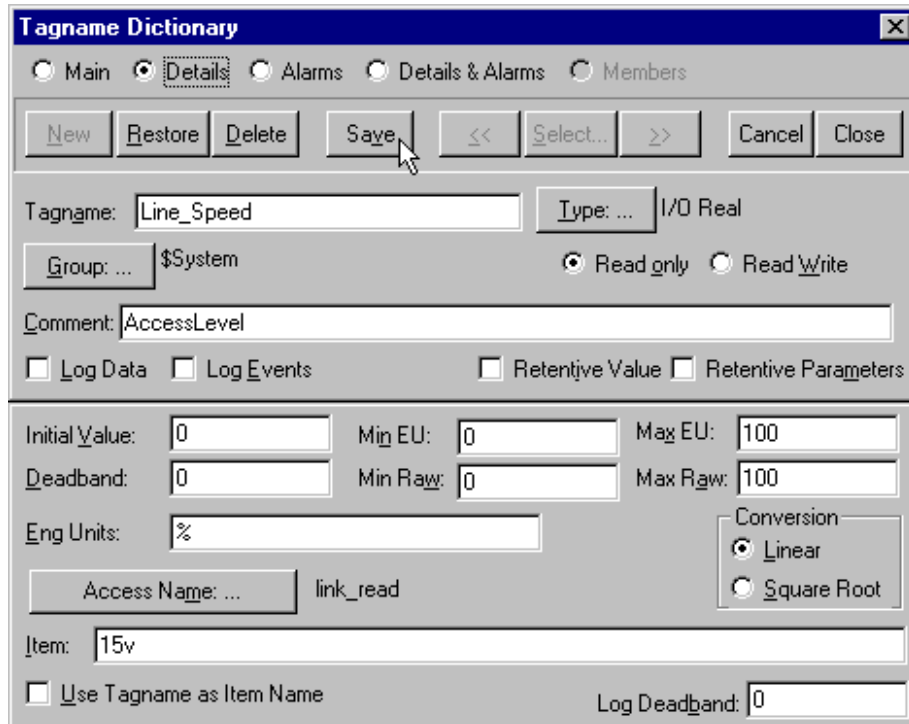

Finally, Enter the slot number to be read in the <Item> textbox. Use the form slot number and the type of data to be sent (V = value, O = ordinal, L = logic) to enter the value. Click on <Save> to finish.

Now that the tagname <Line_Speed> is completed, it can be used in Wonderware to display an analog value for line speed.

To create a slot write tagname, use the example for a slot read with the following changes.

Choose the Read_Write setting.

Select the 'Access Name' for the Desired Link module.

Enter the Link slot number and data type (V,O,L) for the item.

Chapter 6 - Diagnostics & Troubleshooting

If you are having trouble installing the server, there is probably a conflict between the IRQ or I/O mapping parameters selected during setup and the switch settings on the L5204 card.

First, check the card settings and ensure they match the settings of the Link DDE Setup window. If you find a conflict, correct the error and reboot the NT computer for the settings to take effect.

WINRT DEVICE DRIVER

At the lowest level, the Link DDE Server uses a driver named WinRT to handle the interface between the server and the L5204 Card. If, after verifying that the L5204 Card settings match the Link DDE Setup window you are still having problems, check the status of the WinRT driver. Use the Resources tab of the Windows NT Diagnostics to verify the WinRT driver resides at the appropriate IRQ and is active.



As can be seen above, the WinRT driver is present and active on IRQ7. This corresponds to the setup we performed in Chapter 2 - Software Installation.

Next, still using the Resources tab, check address space used by the I/O Port mapping for the WinRT driver.



In this case, the WinRT driver is present and active in the address space from 200 through 23F. Again, this corresponds to the setup we performed in Chapter 2 - Software Installation.

L5204 LED STATUS

If after checking the IRQ and I/O Port mappings, you are still having trouble with the server, check the LED on the L5204 Card. This LED reflects the current state of the Link DDE Server. If after launching the Link DDE Server the LED is anything but solid green, look up the status in Appendix B - Link Card Blink Codes and take the appropriate corrective action.

NT PERFORMANCE MONITOR

Windows NT includes a tool to monitor the performance of applications running on your computer. The Performance Monitor can be found under *Programs\Administrative Tools (Common)\Performance Monitor*.

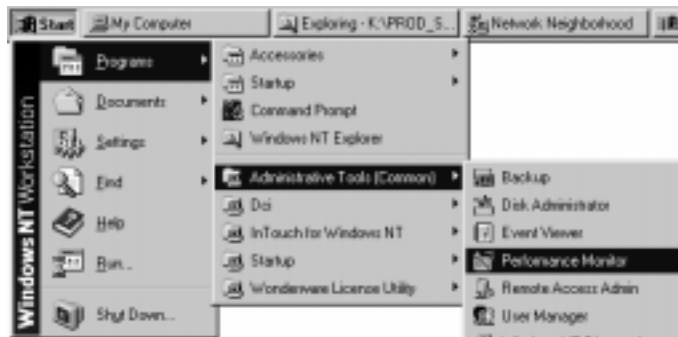

Chapter 6 - Diagnostics & Troubleshooting

After selecting the tool, the Performance Monitor window will appear. In this window, diagnostics for the computer and currently running applications can be displayed. Under the Edit menu, select the Add to Chart item.

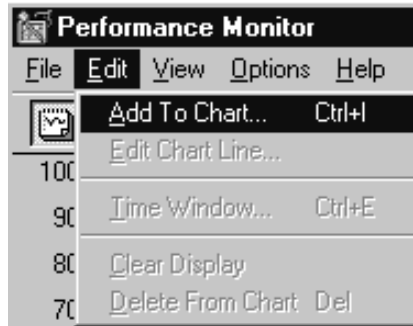

When the Add to Chart window appears, select the Object Link DDE and a list of the available counters will appear in the Counter section of the window. Select the appropriate counter for the diagnostics you wish to perform. For a description of the diagnostic, click on the Explain button and the Counter Description will appear giving details of the diagnostics. Click the Add button after selecting the desired counter to display a trend for the parameter.

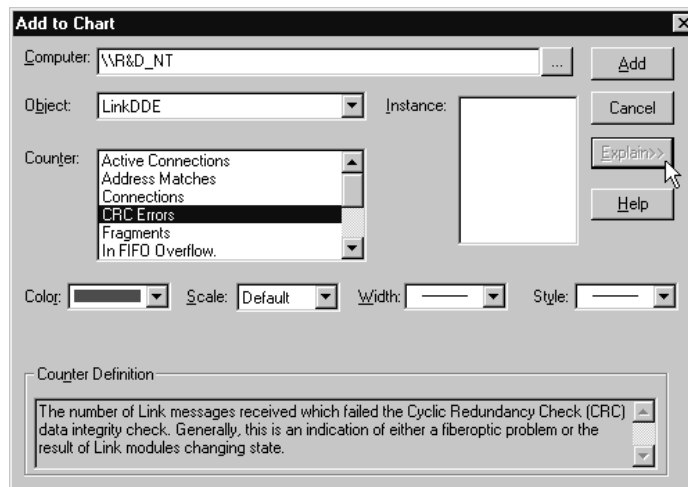

PERFORMANCE MONITOR COUNTERS

The following table describes the counters available in the Performance Monitor for the Link DDE object.

Counter	Counter Definition
Active Connections	The number of active Link connections (input and output) by all Link DDE Clients.
Connections	The number of defined Link connections (input and output) by all Link DDE Clients.
Packets	The number of Link message packets received per second by the Link DDE Server. This number includes all data (XSP) and Link network maintenance messages (NCP,NGP,NNP,SSP,NEP,etc.).
Packets Processed	The number of Link message packets processed per second by the Link DDE Server. This number includes only data messages (XSP).
Address Matches	The number of Link messages which have traversed the entire Link Network without being pulled off by the destination node. Either the destination node has gone offline or a message was generated for a DDE Topic Name that does not exist.
Fragments	The number of Link messages received with a length less than the standard 72-bit message. Generally, this is an indication of either a fiberoptic problem or the result of Link modules changing state.
Overruns	The number of Link messages received with a length greater than the standard 72-bit message. Generally, this is an indication of either a fiberoptic problem or the result of Link modules changing state.
CRC Errors	The number of Link messages received which failed the Cyclic Redundancy Check (CRC) data integrity check. Generally, this is an indication of either a fiberoptic problem or the result of Link modules changing state.
Out FIFO Full	The number of times the Outgoing First-In-First-Out (FIFO) queue on the Link Application Specific Integrated Circuit (ASIC) has filled. If the Out FIFO is consistently full, the outgoing message rate may have to be reduced to provide reliable data transfer.
In FIFO Overflow.	The number of times the Incoming First-In-First-Out (FIFO) queue on the Link Application Specific Integrated Circuit (ASIC) has filled. If overflows persist, the incoming message rate may have to be reduced to provide reliable data transfer.
Link Buffer Overflow	The number of times the Link software buffer has overflowed. Occasional overflows due to message bursts on the Link Network are of no concern. If the Link buffer overflows degrade performance, it may be necessary to increase the Link Buffer Size in the Link DDE Setup Window.

Link Network Loading

The Packets and Packets Processed Counters can be used to determine Link Network loading. The bandwidth of the Link Network is approximately 12000 messages/second.

Configuration Problems

The Address Matches Counter can be used to determine if there are unnecessary messages being generated by the application using the Link DDE Server. This counter reflects the number of messages that have traveled the entire fiber optic ring and were pulled off by the Server. If all modules are on-line and the Address Matches counter continues to increment, check your application for DDE connections to modules which are no longer present.

Network Problems

The Fragments, Overruns, and CRC Errors Counters are indications of fiber optic problems on the data being received from the module upstream of the Server on the Link Network. Generally, these counters should be zero (or some small value if you have been reconfiguring modules on the network causing changes of state). If these counters are continuously incrementing, check the light intensities on the Link Network and inspect upstream fiber optic cable.

Server Performance Problems

The Out FIFO Full, In FIFO Overflow, and Link Buffer Overflow Counters will all be zero unless there are either Link Network loading issues or computer resource problems. To correct problems with these buffers overflowing, refer to the detailed descriptions in the Advanced Settings section of Chapter 2 - Software Installation.

Setup Problems

The following error could appear if the I/O Port address in the Link DDE setup does not match the actual I/O Port Address on the Link DDE card. The error is "Initialization of the dynamic link library C:\Program Files\DCI\LinkDDE\Ssdlink.dll failed." Refer back to chapter 2 for instructions on how to setup the I/O Port Address.

Chapter 7 - Uninstalling the Server

As with most Windows NT compatible applications, the Link DDE NT Server may be uninstalled using the Add/Remove Programs feature of the Control Panel. You must be logged on as the Administrator in order to remove Link DDE from your NT computer. Select the Settings menu item under the Start Menu, and then select the Control Panel item from the list.

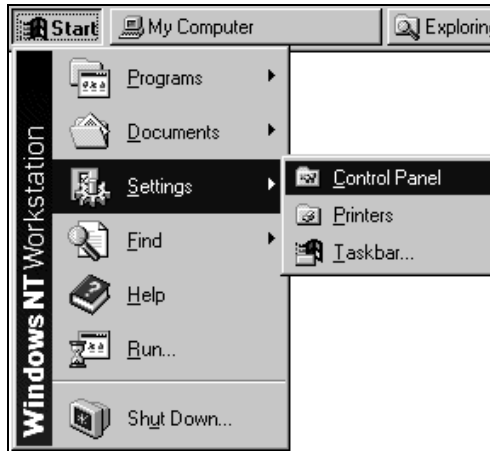

The Control Panel will appear as shown below. Double-click the Add/Remove Programs icon in the folder.

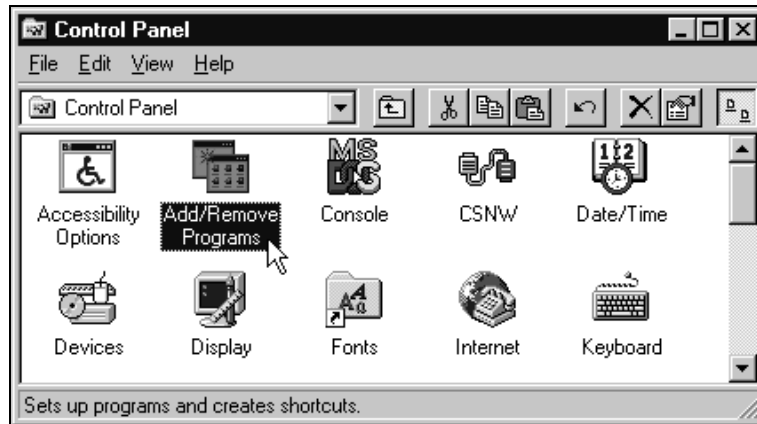

When the Add/Remove Programs Properties window appears, select Link DDE from the list and then click on the Add/Remove button.

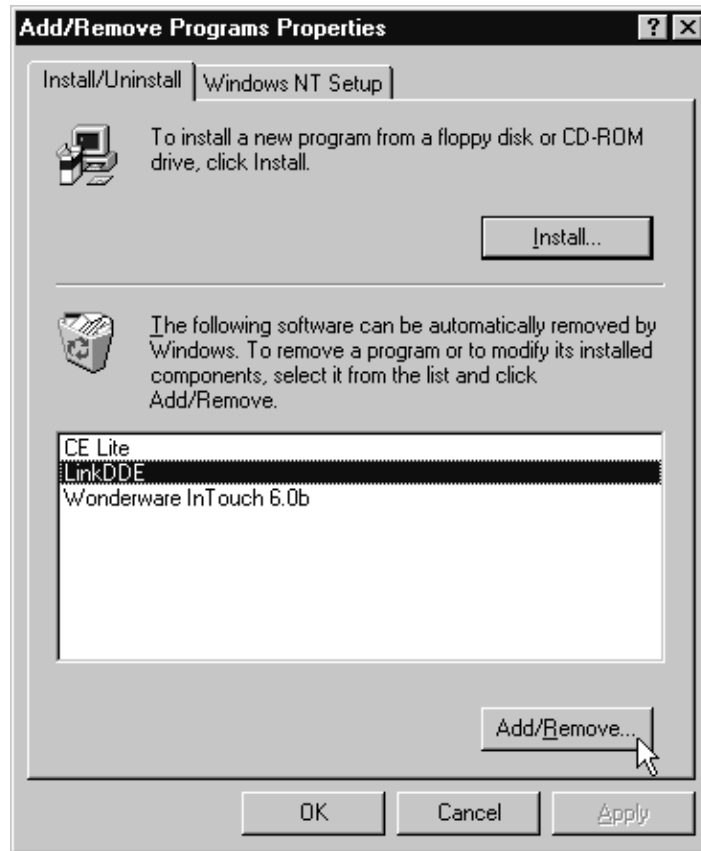

At this point, the Uninstall program will ask you to confirm the removal of the Link DDE Server. Answer Yes to continue.

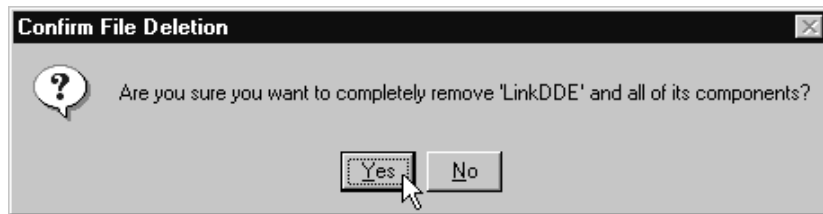

More than likely, there will be shared files the Uninstall Program identifies as no longer in use. Generally, it is safe to remove these files so choose the Yes button.

To All choice when it appears. If you have any question about retaining files, you may use the Yes and No buttons to individually determine which files will be retained. If you wish to retain all files, click the No to All button.

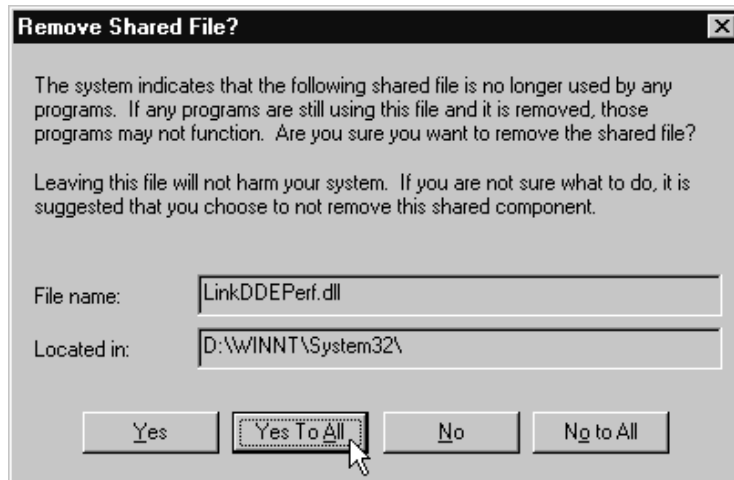

When you chose the Yes to all button, a *Remove Shared File?* confirmation window will appear for you to confirm the removal of all the files. Choose the appropriate response.

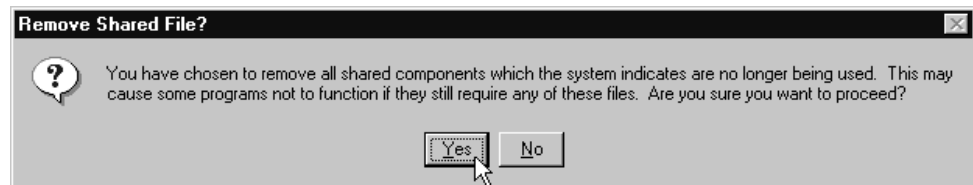

At this point, the Uninstall wizard will remove all the files, folders and NT Registry entries from your computer.



Path Setting

The only setting which will not be automatically removed by the Uninstall Wizard is the Path variable added to your NT Environment during the software installation process. To remove this setting, return to the Start Menu and under *Settings*, select the *Control Panel* and then double-click the *System* icon.

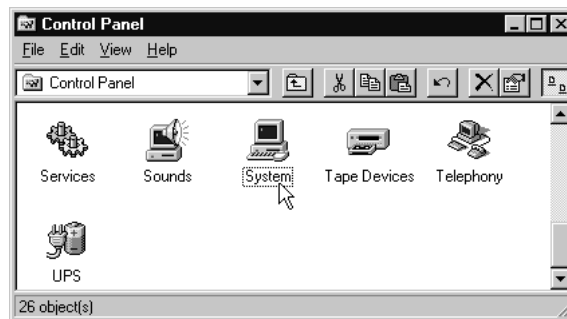

Chapter 7 - Uninstalling the Server

When the *System Properties* window appears, click the *Environment* tab and then highlight the Path Variable in the System Variables list. Highlight the portion of the path associated with the Link DDE Server in the Value field at the bottom of the window. Press the *Delete* button and then the *Apply* button. This completes the uninstall of the Server.



Appendix A - L5206 Repeater Data Sheet

GENERAL DESCRIPTION

The L5206-2-01 Link Gateway Repeater receives and retransmits data between the Link fiber optic network and all Link Gateways. The gateway is connected via a shielded cable (CM350901) to the repeater's DB25 connector. The L5206-2-01 behaves identically to a simple repeater when the gateway is absent. When a gateway is connected to the repeater, network data is routed through the gateway to include it in the Link network ring.

The Link Repeater is housed in a NEMA 4 enclosure suitable for mounting outside equipment enclosures or in unprotected environments.

Appendix A - L5206 Repeater Data Sheet

The L5206-2-01 supports the transmission of two Link channels. Either a primary and secondary channel pair, or two discrete primary channels may be retransmitted.

TECHNICAL SPECIFICATIONS

ENVIRONMENTAL Operating temperature 0°C to 50°C Storage temperature -10 °C to +70 °C Humidity 85% R.H. in a dry, non-condensing environment Enclosure Rating NEMA 4, IP-66 (with appropriate waterproof 1/2 inch NPT fittings)	FIBER OPTIC CHANNELS Transmission Distance Selected by toggle switches. SW1 controls FO4 transmitter and SW2 controls FO2 transmitter LOW (center position) Up to 66 feet (20 meters) MEDIUM (left position) 66 to 131 feet (20 to 40 meters) HIGH (right position) 131 to 197 feet (40 to 60 meters)
SUPPLY Supply Voltage 20 to 28 VDC (24VDC nominal) Current Consumption 55 mA maximum Power Dissipation 1.5 Watts maximum Power Terminals 14 to 22 gauge (0.5 to 1.5 mm ²) wire size	PHYSICAL Height 6.89 inches (175 mm) Width 3.15 inches (80 mm) Depth 2.32 inches (59 mm) Weight 1.35 lb. (0.61 kg)

CONNECTION DIAGRAMS

The fiber optic cable connections for each channel are shown below. Note that the arrow denotes the direction of transmission in the fiber, from transmitter to receiver. Each channel is completely independent and hence, can be used either as a primary or a secondary channel.

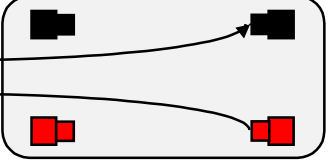
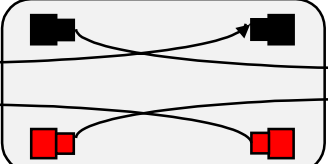
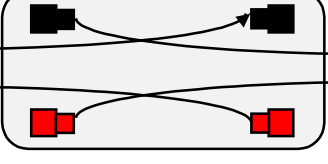
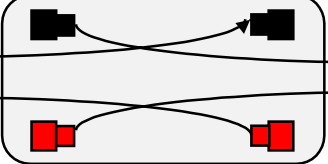
<p>Primary Channel</p> 	<p>Network Topology</p>	<p>Effect when NT Server is closed</p>
	<p>Simple</p>	<p>Network ring is broken.</p>
<p>Main Ring Subsidiary Ring</p> 	<p>Network Topology</p>	<p>Effect when NT Server is closed</p>
	<p>Tapped</p>	<p>Network ring is preserved *</p>
<p>Main Ring Subsidiary Ring</p> 	<p>Network Topology</p>	<p>Effect when NT Server is closed</p>
	<p>Auxiliary Tapped</p>	<p>Network ring is preserved *</p>
<p>Primary Channel Secondary Channel</p> 	<p>Network Topology</p>	<p>Effect when NT Server is closed</p>
	<p>Redundant</p>	<p>Network ring is preserved</p>

* NOTE: Losing a fiber optic signal at either receiver breaks both rings.

Appendix B - Link Card Blink Codes

The L5204 -DDE-NT Interface Card used by the Server to communicate with the Link network has a tricolor (Red, Green, Amber) LED which provides the user with a quick and easy method of determining the card's state. The bLink codes for the card are described below:

INITIALIZATION (STATUS 0)



While in initialization, the DDE Server prepares itself to run. It first performs a self-test, and then executes its initialization tasks (including reading configuration data out of the battery backed up RAM, setting up data structures, etc.). If the card stays in this state for an extended period after the initial set-up, a hardware failure is suspected and the unit should be replaced.

HALTED (STATUS 1)

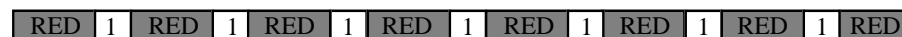

Indicates that the DDE Server has stopped as the result of a software tools request. The DDE Server may be restarted using Eurotherm Drives' ConfigEd software package and message processing will continue.

NO CONFIGURATION (STATUS 2)



Indicates that the DDE Server is unable to run because it has no configuration or the configuration has been corrupted. Install a valid configuration using the DDE Server Config software package.

L ERROR (STATUS 3)

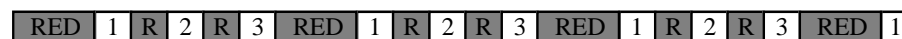

Indicates that the DDE Server has stopped due to a low-level internal error. Check for Link connections to slots receiving messages at very high data rates, temporarily stop sending the data from the source node, and reset the DDE Server. Also, could be an indication of hardware failure. If the problem persists, contact Technical Support.

H ERROR (STATUS 4)

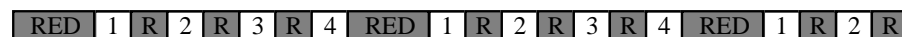

Indicates that the DDE Server has stopped due to a high-level internal error. Reset the DDE Server. If the problem persists, contact Technical Support.

SELF TEST FAILURE (STATUS 5)



Indicates that the DDE Server has stopped due to a hardware error.

SHUTDOWN (STATUS 6)



Indicates that the DDE Server is in the process of shutting itself down. If the DDE Server stays in this state for an extended period, a hardware failure is suspected.

OK (STATUS 7)



Indicates that the DDE Server is running and no fatal errors exist.

NETWORK WARNING (STATUS 8)



For non-redundant topologies, indicates the Link ring was broken for less than 1 second. For redundant topologies, either the forward and reverse transmission path is broken. If problem persists, check the integrity of the fiberoptic ring.

NETWORK FAILURE (STATUS 9)



For non-redundant topologies, the Link ring has been broken for greater than 1 second. For redundant topologies, both the forward and reverse transmission paths have been broken. The DDE Server is permanently configured NOT to restart on a Link Network fail.

Depending on the topology selected, this fault can also be caused by improperly connecting fiberoptic cables to the L5206 Gateway Repeater.

CHECKING NETWORK (STATUS A)



Indicates that the DDE Server is ready to start but is unable to send a message to itself around the ring to verify that the ring is complete. Check for disconnected modules, loose connections, and un-powered modules. Check the power to the L5206 Gateway Repeater. Check the L5206 Gateway Repeater cable for continuity per Appendix B.

PEER HALTED (STATUS B)



Indicates that the DDE Server is ready to start but is waiting for other modules on the network to become ready to start. Check for modules that are halted or in an error state. The system will not run until all the modules are ready.

DUPLICATE ADDRESS (STATUS C)



Indicates that the DDE Server has discovered a duplicate address on the network and has removed itself from the network and stopped. If a system has two or more modules with the same address, it cannot run. Correct the problem by reconfiguring or restoring one of the offending modules using the ConfigEd software package.

Appendix C - Link Card Cable

In troubleshooting the NT Server, it may become necessary to check the continuity of the cable assembly. The pinout of the Link Cable Assembly (CM350901) is shown below:

WARNING!

Ensure that all power supplies have been removed prior to disconnecting the Cable Assembly from the card. Disconnect the cable from both the Link card in the X-Link and the repeater prior to performing any electrical checks.

Caution

Ensure the probe does not exceed the diameter of the male pins that are normally inserted into the connector. Permanent damage may result.

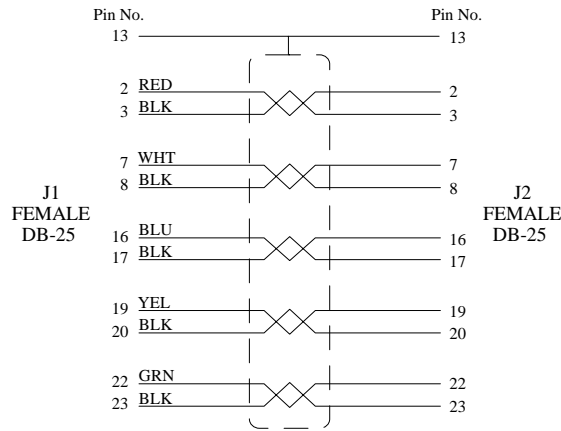

CM350901 Pinout

Location of the pins in the DB-25 connector are typically marked on the connector per the layout depicted below:

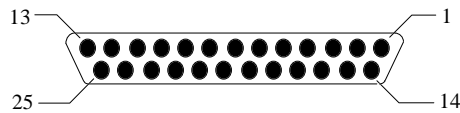

End View of DB-25 Connector

Note: This cable is NEVER to exceed 36 inches in length from the strain relief of the J1 connector to the strain relief of the J2 connector.